

HP 9830
Service ROM Card
Schematic

NOTES

- The symbol  represents a connector pin. The solid black end is the male side, the white-filled end is the female side.
- 2024 May: Initial drawing / bhlpert.

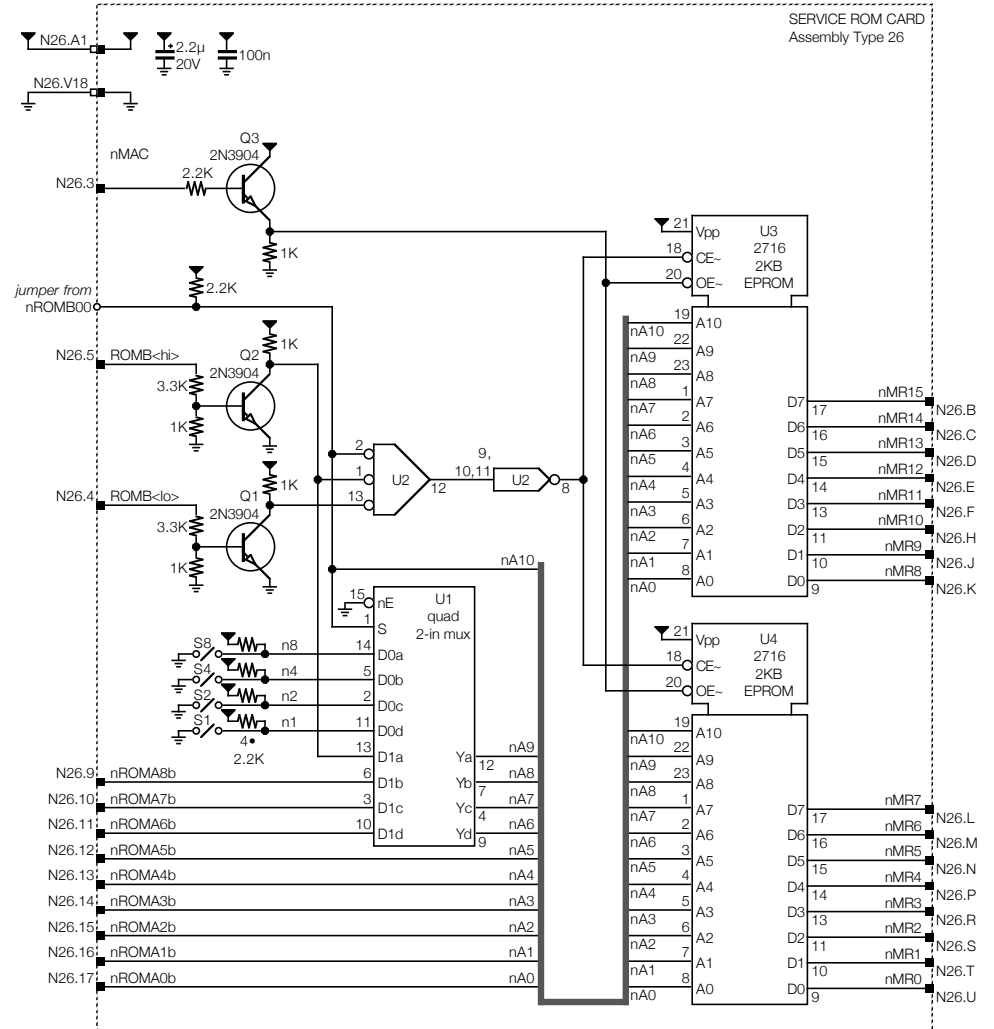
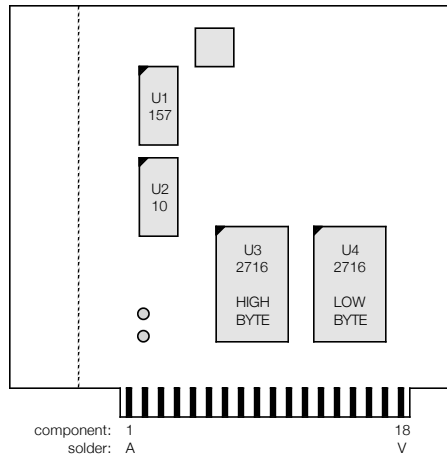
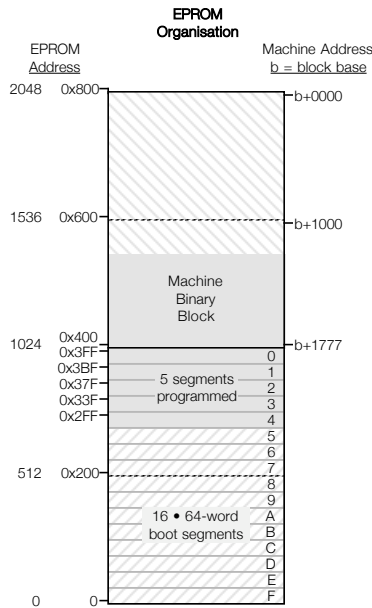

Ux	Type	a	b	c	d	e	f	Type	Qty	Pins	V+5	GND
1	74157	✓	✓	✓	✓			7410	1	14	14	7
2	7410		u	✓	✓			74157	1	16	16	8
3	2716			✓				2716	2	24	24	12
4	2716			✓								

Total: 4

Total ICs: 4

HP 9830 Computer

Section: Service ROM Card

Page: 2

Rendition: Jul 5, 2024

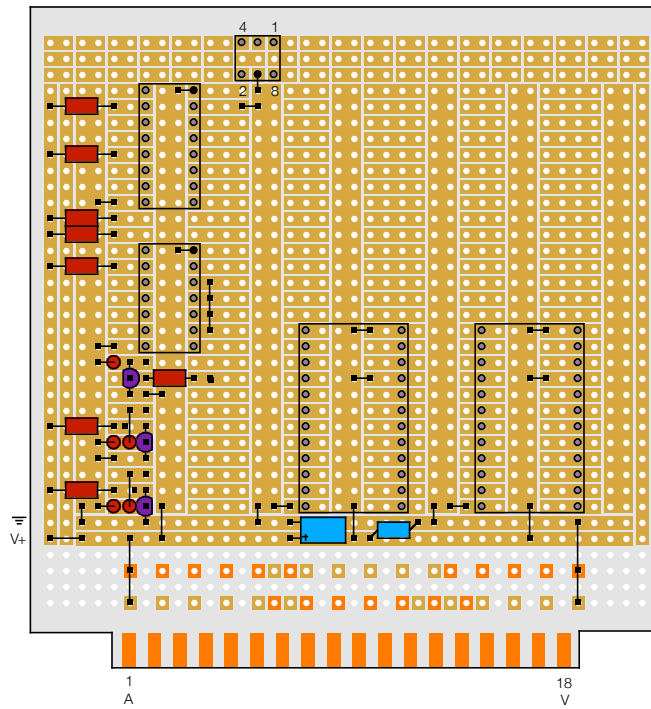

HP 9830 Computer

Section: Service ROM Card

Page: 3

Rendition: Jul 5, 2024