

Notes

- Band coils shown for Broadcast band (A). See manufacturer schematic for other band coils.
- Capacitance in microfarads unless otherwise indicated.
- This is a re-drawing of a scanned version of the manufacturer schematic from RadioAmateur.eu. Some part numbers and values were blurred in the scan, for surety they should be checked against the parts list in the manual, if in question.
- Initial drawing: 2019 Apr / bhilpert.

Hammarlund SP-600 Receiver

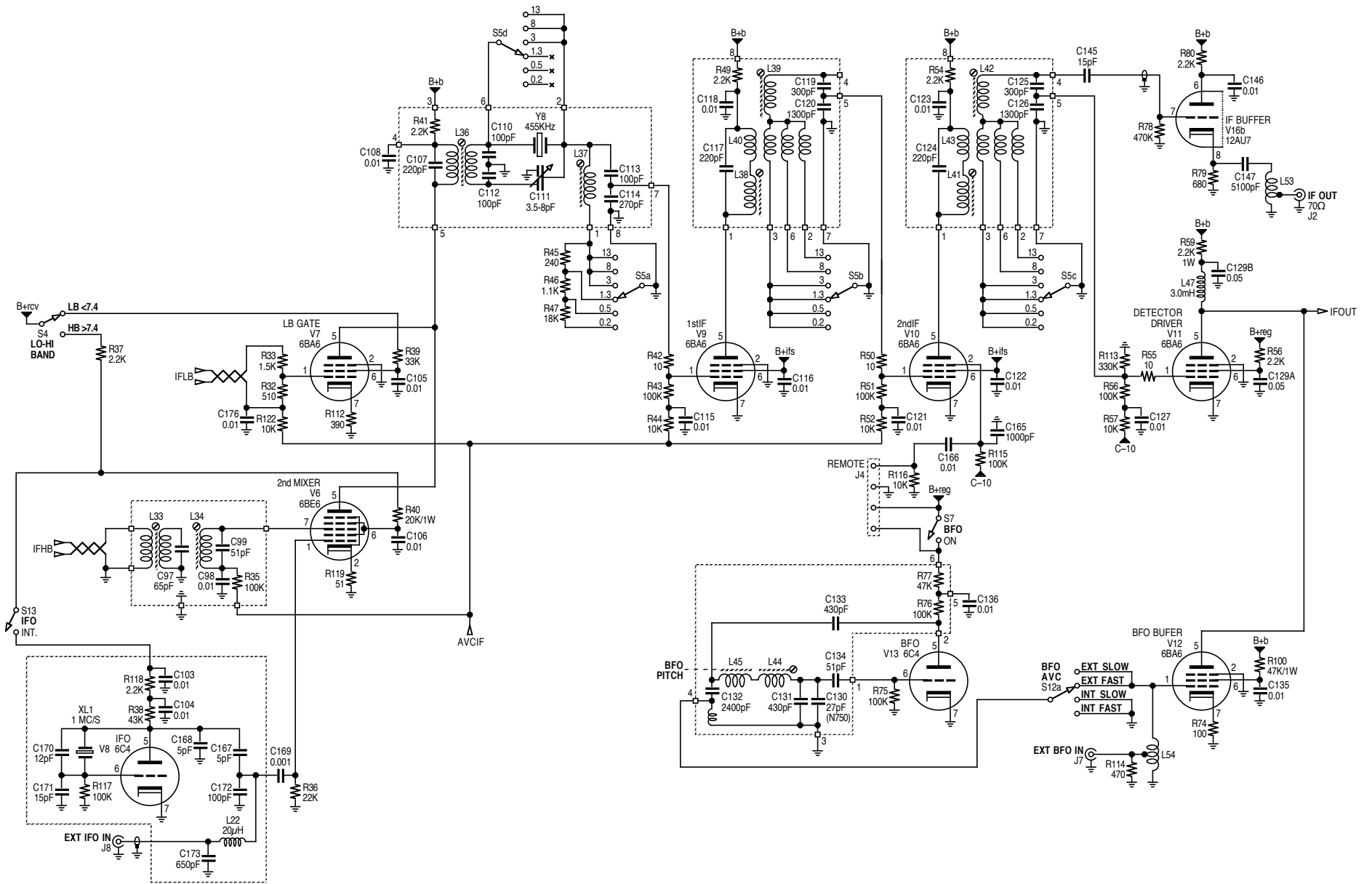

Hammarlund SP-600 Receiver

Section: IF, BFO

Page: 2

Dwg. Rev.: 2019 May 4

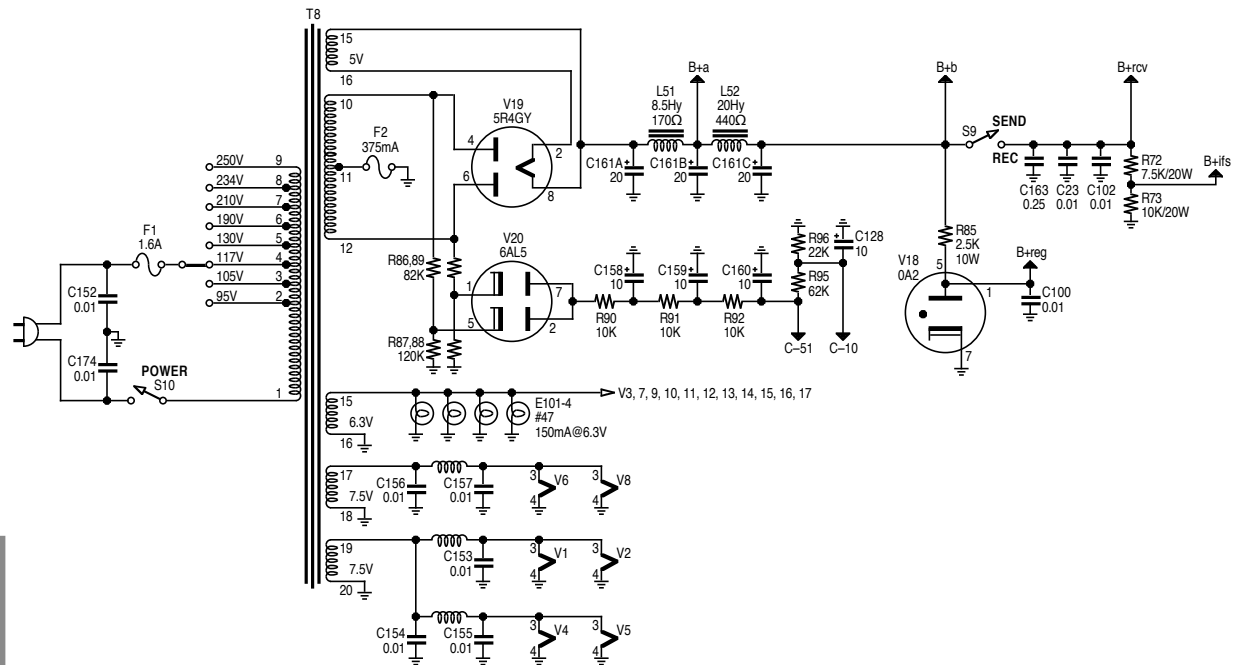
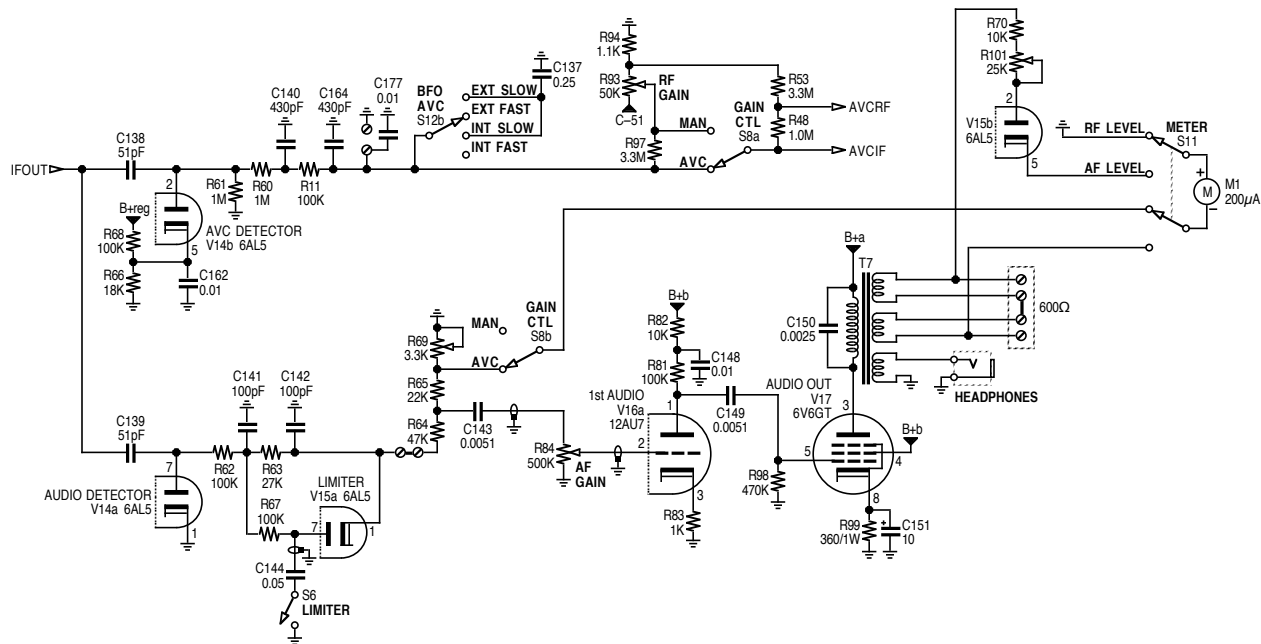

Hammarlund SP-600 Receiver